

Components

- 1) Apogee Remote Control via Mobile Phone Electronic Kit MK160
- 2) Two dual electrical outlets (15 amp)
- 3) Wire - AWG14 or AWG12
- 4) 3- 4 electrical pigtails
- 5) 100ma power source for Apogee PC (120v plug - in - power source)
- 6) 6x6x6 project box (Home Depot)
- 7) 120v power chord with male plug-in
- 8) Solder for wire pigtails
- 9) Sheetmetal (installed as a shelf for cell - phone over light sensor)
- 10) Pop -Rivets (holds sheetmetal shelf in place)
- 11) Foam insulation (installed between cell - phone and sheetmetal)
- 12) Hot glue (secures transformers, PC board, etc.)

Most components can be purchased at the local hardware store

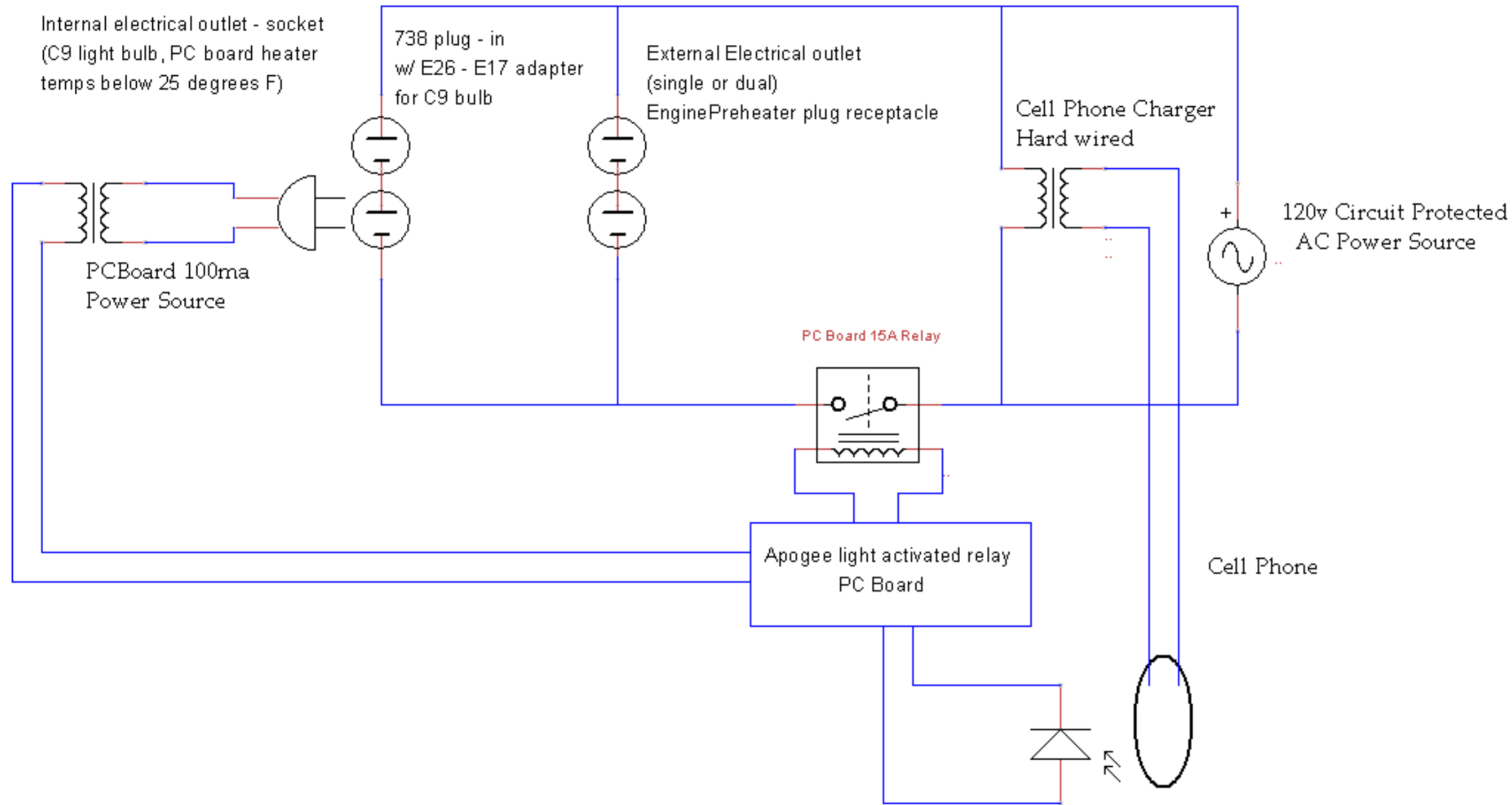

Title Engine Preheater Switch Box		
Author <i>www.JoesPiper.com</i>		
File	D:\Documents\Switch.dsn	Document
Revision 1.0	Date November 2010	Sheets 1 of 1